

POWERKEY PRO PKP-2200-SI



DESIGN YOUR OWN
PROTOTYPE ONLINE



CANopen
J1939



FLEXIBLE - SMART - RUGGED

PKP-2200-SI is a compact keypad based on CAN protocol. It comes equipped with four keys with interchangeable 15 mm inserts. The keypad is water and dust resistant, and can be installed both inside and outside the cockpit. RGB led lights and the ease with which icons can be switched in and out make it possible for the user to customize each key in a wide range of variations.

SOFTWARE FEATURES

CAN and RS485 Keypad Addresses – Assign any valid CAN and RS485 address to the keypad. Communicate on either BUS simultaneously.

J1939 Address Claim Transmission – Keypads no longer have to be pre-programmed to a specific address. This enables customers that work in applications in the field without access to a GUI to use any replacement keypad on-hand. The keypad can be configured to automatically announce its address and accept a new address assignment as appropriate.

Event Status Transmission – The keypad can send messages to the BUS indicating a button press or a button release event has occurred. This confirmation allows digital systems to have the same input acknowledgements as that of the latching position of a mechanical switch.

Periodic Status Transmission – The keypad sends a continuous broadcast of messages indicating the press or release status of each button at that instance. The frequency of these messages can be adjusted in a wide range.

Online Set-up – An online set-up system makes it possible to select and design your own prototype, then order it directly on blinkmarine.com.

Periodic Heartbeat – The keypad sends a continuous broadcast of messages indicating it is functioning correctly. The frequency of these messages can be adjusted in a wide range.

HARDWARE FEATURES

IP67/IP69K waterproof rating – Guaranteed to be dust tight and sealed against water immersion to a depth of 1 meter for up to 1 hour. The IP69K rating provides protection against high pressure water at high temperature spray downs.

UV Protected – UVB 400 hours: Keypad is highly resistant to deterioration caused by exposure to sunlight.

Customizable inserts – The replacement system for individual inserts makes modifying the keypad layout simpler and more economical. Hundreds of different stock inserts can be viewed at blinkmarine.com, and it is possible to order customized ones.

A membrane compensation valve which self compensate the internal pressure within the keypad, alleviating mechanical stresses that can be produced by shifts in external temperatures.

The keypad's symmetrical design and spacing between keys makes it easier to install multiple keypads alongside one another.

The rubber is molded on the backside in such a way that it acts as a gasket, blocking liquids and preventing them from leaking in through the attachment holes located on the support upon which the keypad is installed.

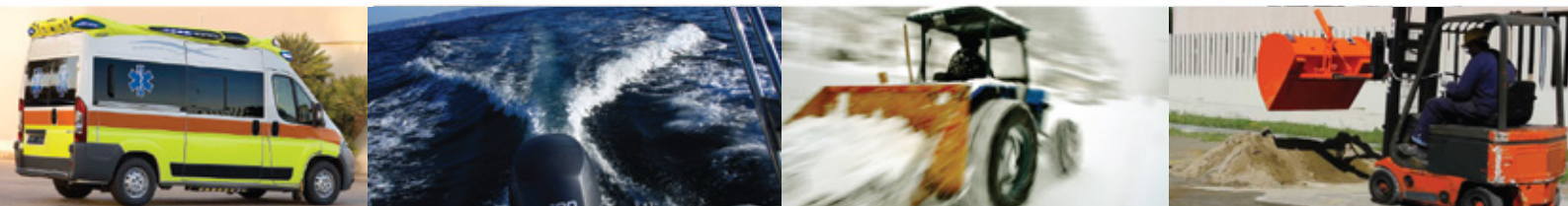

Icons shown on this keypad are for visual demonstration only.

STANDARD FEATURES

- Reconfigurable keys
- Relegendable buttons
- LED state & status configurable
- Vertical or horizontal mount
- Flush or front mount
- LED backlit icons
- Multicolor indicator rings
- Laser etched icons
- ON/OFF, momentary, toggle & scroll
- Hundreds of stock icons to choose from

SOFTWARE FEATURES

- Change CAN or RS485 keypad addresses independently
- Periodic status transmission
- Heartbeat
- Event status transmission
- LED acknowledgement
- Address claim transmission
- RS485, CANopen and J1939

OTHER BENEFITS

- Programmer's manual available to help support plug-and-play reconfigurability

SPECIFICATIONS FOR STANDARD KEYPADS

ELECTRICAL

Supply Voltage	12-24Vdc Nominal (8-32VDC)
Standby Current	<50 mA
Communication BUS	RS485, CANopen, J1939

MECHANICAL

Connector	Deutsch DT04-4P
Switch Life	3 million operations
Mounting Studs	#10-32 CDA-510 phosphor bronze, electroplated bright tin
Keypad	Silicone rubber with polyurethane hardcoat
PC Board	1,6mm thick, Nema Grade FR-4, double clad with 1oz copper
Operating Temperature	-40°C to +70°C
Storage Temperature	-40°C to +85°C
Thermal Shock	-40°C to +85°C According to table 2 of ISO16750-4
UV Protection	UVB 400 hours
Salt Spray	Per ASTM B117
Chemical Resistance	Deet, Engine Cleaner, Isopropyl Alcohol, Suntan Lotion, Multi-Purpose Cleaner, Orange Citrus Cleaner, Muriatic Acid
Ingress protection Rating	IP67/IP69K

blink

M A R I N E

Blink S.r.l.

Via Montefeltro, 6 - 20156 Milano - Italy

Tel. +39 02 3088583 - Fax +39 02 33406697

www.blinkmarine.com - info@blinkgroup.com

!WARNING! IMPROPER SELECTION, IMPROPER USE AND/OR FAILURE OF THE BLINK SYSTEMS PRODUCTS DESCRIBED HEREIN OR RELATED ITEMS CAN CAUSE DEATH, PERSONAL INJURY AND PROPERTY DAMAGE. This document and other information from Blink, provide product and/or system options for further investigation by users having technical expertise. It is important to analyze all aspects of the application, including consequences of any failure. Due to the variety of operating conditions and applications for these product[s], the manufacturer of the application is solely responsible for marking the final selection of the product[s] and assuring that all performance, safety and warning requirements of the application are met. The products described herein, including without limitation, product features, specifications, designs, availability and pricing, are subject to change by Blink at any time without notice.

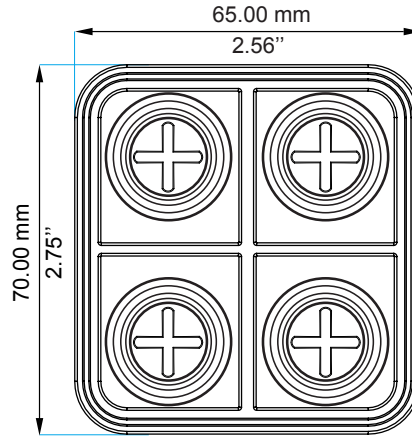

GREEN= TxRx-(RS485) ORANGE= TxRx+(RS485)
 BLACK=GROUND WHITE=CAN HIGH
 RED=POWER BLUE=CAN LOW

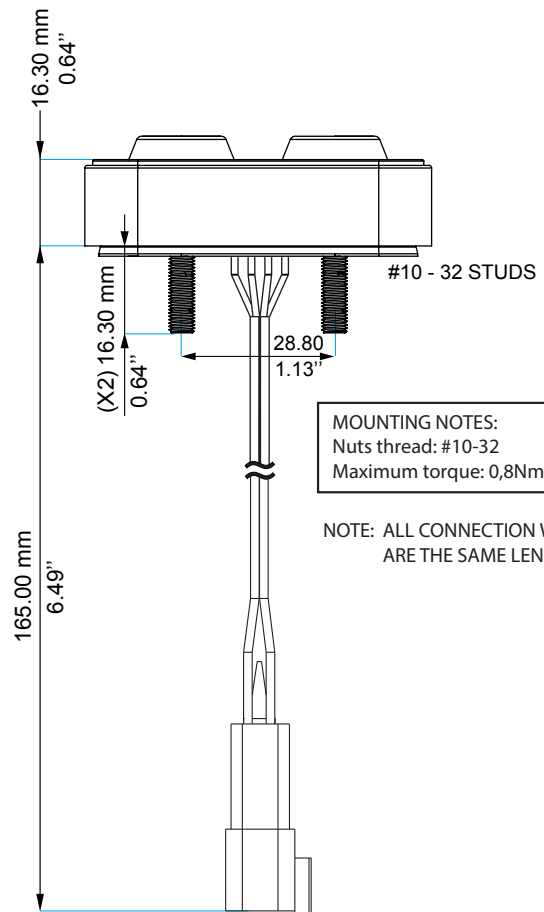
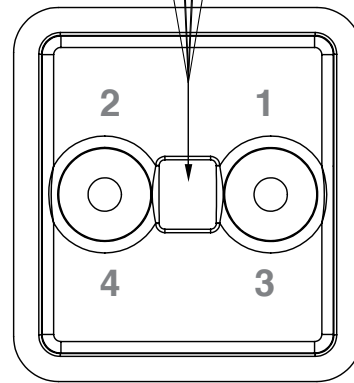

MOUNTING NOTES:
 Nuts thread: #10-32
 Maximum torque: 0,8Nm

NOTE: ALL CONNECTION WIRES ARE THE SAME LENGTH